

Toggle Clamps

Hold Down, Vertical Handle (Straight Base)

■ Features: MC04-5S is Straight Base, Welded Tip Type.

Part Number	MC04-1S	MC04-2S	MC04-5S
Body Material	SS400	SS400	SS400
Surface Treatment	Trivalent Chromate	Trivalent Chromate	Trivalent Chromate
Tightening Force (N)	441	882	2270
Weight (g)	60	170	355
Arm Open-Close Angle	100°	95°	100°
Handle Open-Close Angle	56°	60°	56°
Accessory	Bolt with Rubber Material: NBR Hardness: Shore A70	Bolt with Rubber Material: NBR Hardness: Shore A70	Bolt with Rubber Material: NBR Hardness: Shore A70
Unit Price			

1N=0.101972kgf

MC04-1S

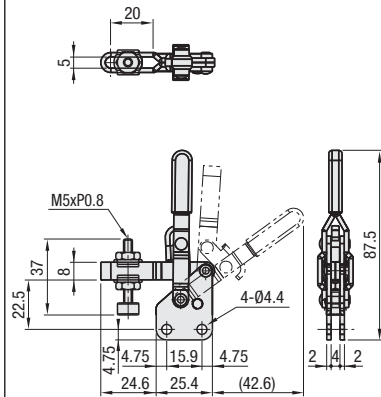

MC04-2S

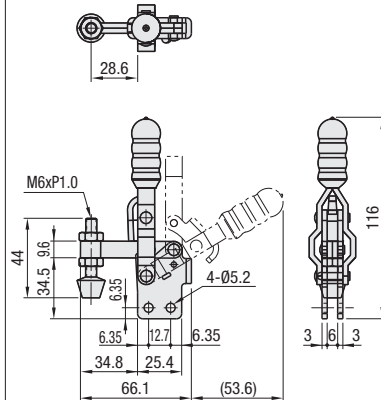

MC04-5S

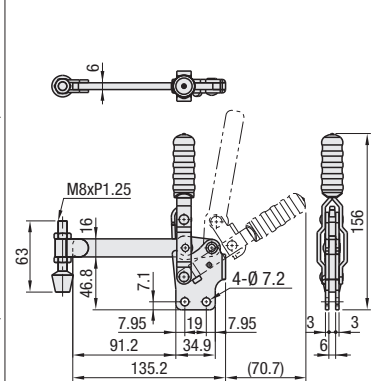

Part Number	MC04-3S	MC04-4S
Body Material	SS400	SS400
Surface Treatment	Trivalent Chromate	Trivalent Chromate
Tightening Force (N)	2205	3332
Weight (g)	355	635
Arm Open-Close Angle	100°	112°
Handle Open-Close Angle	56°	61°
Accessory	Bolt with Rubber Material: NBR Hardness: Shore A70	Bolt with Rubber Material: NBR Hardness: Shore A70
Unit Price		

MC04-3S

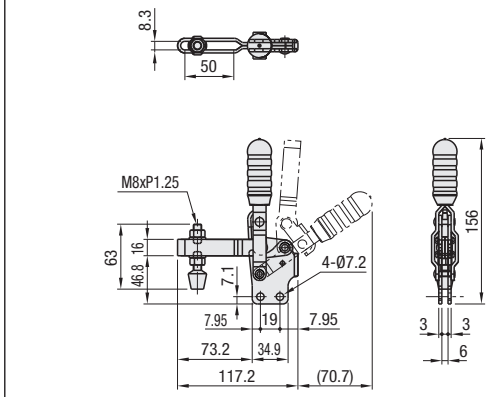

MC04-4S

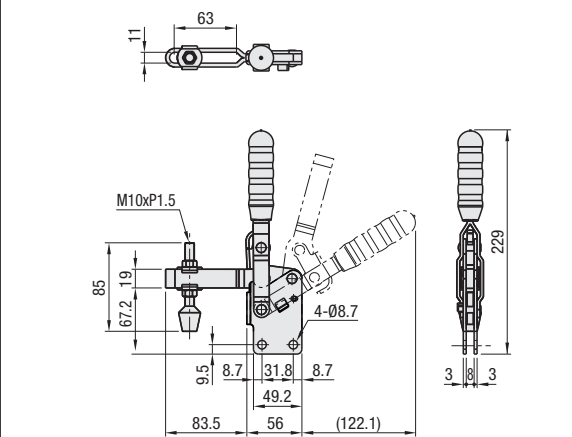

Ordering Example Part Number MC04-1S

ex Example Combination of these app. examples can be selected on our website. Selection Procedure Details P.87

e-Catalog Search Keyword #MA473 Search



Toggle Clamps

Hold Down, Vertical Handle, Long Arm (Flange Base)

Part Number	MC04-1L	MC04-2L
Body Material	SS400	SS400
Surface Treatment	Trivalent Chromate	Trivalent Chromate
Tightening Force (N)	186	392
Weight (g)	75	175
Arm Open-Close Angle	100°	95°
Handle Open-Close Angle	56°	60°
Accessory	Bolt with Rubber Material: NBR Hardness: Shore A70	Bolt with Rubber Material: NBR Hardness: Shore A70
Unit Price		

1N=0.101972kgf

MC04-1L (Long Arm)

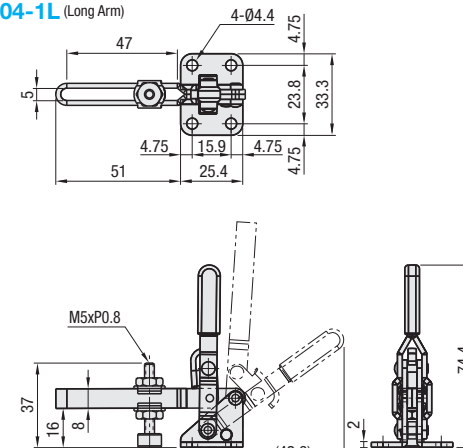

MC04-2L (Long Arm)

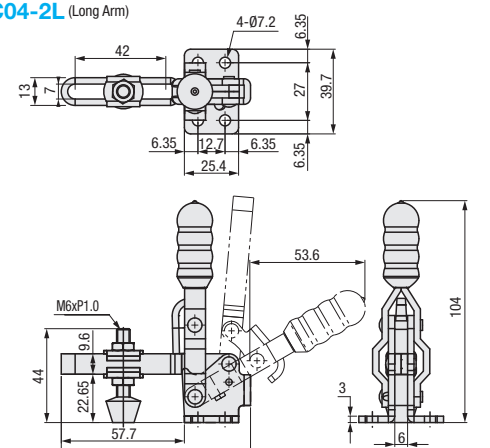

Part Number	MC04-3L	MC04-4L
Body Material	SS400	SS400
Surface Treatment	Trivalent Chromate	Trivalent Chromate
Tightening Force (N)	784	1078
Weight (g)	370	815
Arm Open-Close Angle	100°	112°
Handle Open-Close Angle	56°	61°
Accessory	Bolt with Rubber Material: NBR Hardness: Shore A70	Bolt with Rubber Material: NBR Hardness: Shore A70
Unit Price		

MC04-3L (Long Arm)

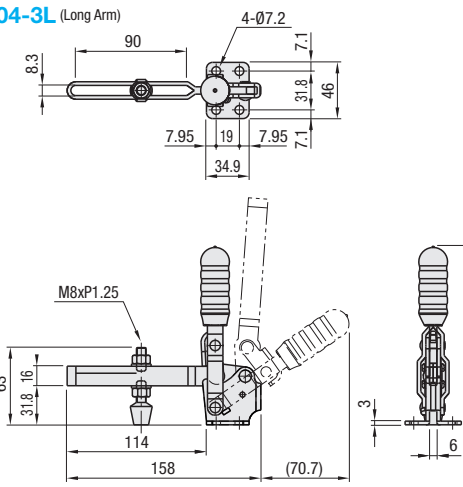

MC04-4L (Long Arm)

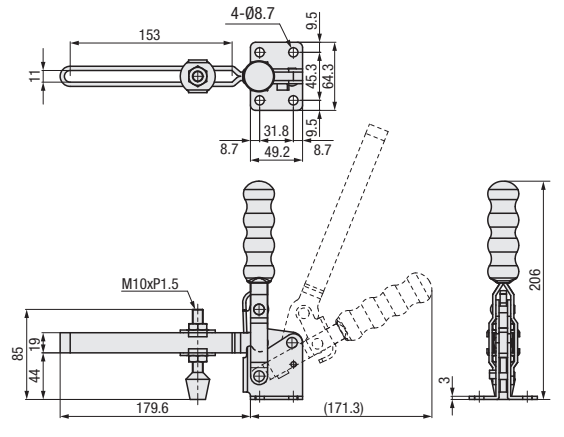

Ordering Example Part Number MC04-3L

ex Example Combination of these app. examples can be selected on our website. Selection Procedure Details P.87

e-Catalog Search Keyword #MA553 Search

