

Installation and Maintenance of Linear Guides

Installation Method of Linear Guides

MISUMI Linear Guides have a datum surface (a surface with a straight groove) on both the rail and block. (See the diagram below.)
When installing Linear Guides, correctly match the datum of the guides and installation bases.

Miniature Linear Guides Common to Existing and C-VALUE Products	Linear Guides for Medium/Heavy Load		
	Existing Products	Existing Products (with Plastic Retainer)	C-VALUE Products

Mounting Surface Shape

Linear Guides are designed to obtain accuracies when mounted on base plates. Generally, the datum plane is placed against the shoulder on the mounting surface. In that case, corners should have reliefs or corner radius should be machined smaller than chamfering of rails and blocks. See each product page for chamfering dimensions of products.

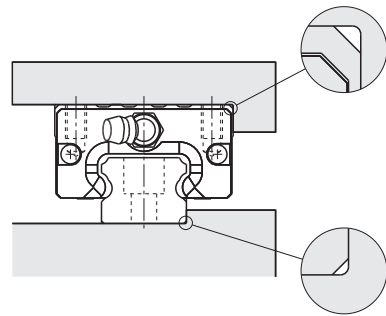

Block Mounting Surface Flatness

Blocks may be deformed depending on its mounting surface flatness. Block deformation may cause clearance, which might give less/more preload and cause sliding defects. Securing 5μ mounting surface flatness is recommended.

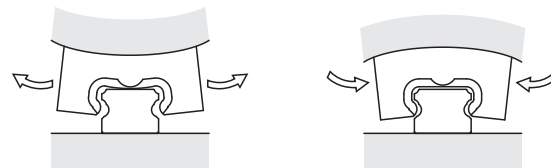

Installation Error Tolerance

Installation Error Tolerance is the value which does not influence operating life under common usage.

Running Parallelism Error Tolerance		Height Error Tolerance	

Installation Error Tolerance				
Type	Radial Clearance	Parallelism Error Tolerance of 2 Axes (P)	Height Error Tolerance of 2 Axes (S)	
Existing Products	Light Preload, Normal Clearance	20μm or Less	330μm or Less / 500mm	
C-VALUE Products	Normal Clearance	H24 H28 H30	25μm or Less	
		H33 H36 H40	30μm or Less	
		H42 H45	40μm or Less	
		Miniature Type	6μm or Less	
(Common to Existing and C-VALUE Products)	Slight Clearance	10μm or Less	30μm or Less / 200mm	

Rail Installation

When datum is provided on installation bases

- Remove burrs and dusts on the mounting surfaces before installation.
- Place a rail on the installation side of the base gently, and tighten the screws temporarily while pushing the rail against the datum shoulder.
- Installation methods Fig. 1-3 are recommended when using linear guides where shocks, vibrations and heavy loads may exist, and high precision is required.
- Fully tighten the rail mounting screws to specified torque with a torque wrench. (For torque standards, see Table-1.)

Fig.1: Push Plate Method

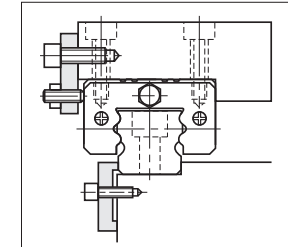

Fig.2: Taper Gib Method

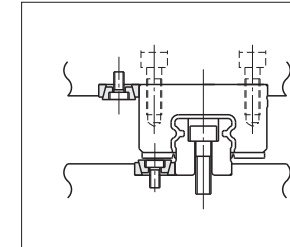
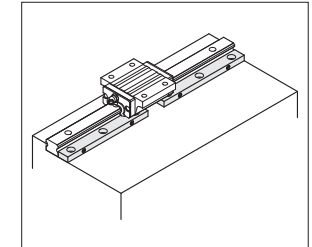

Fig.3: Push Screw Method



When datum is not provided on installation bases

- Straight Gauge
- Place a rail on the installation side of the base gently, and tighten the screws temporarily.
 - Place a straightedge parallel to the temporarily tightened rail.
 - Use the straightedge as a reference, snug down the screws while measuring the parallelism of the rail with a dial indicator as shown in Fig.4.
 - Fully tighten the rail mounting screws to specified torque with a torque wrench.
 - The secondary rail can be installed in the same straightedge method as the primary master rail, or by using the primary rail as a datum reference. In either method, use a dial indicator to measure the parallelism while the rail is being fastened down.

Fig.4: Straightedge Method

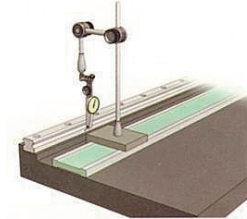

Fig.5: Secondary Rail Mounting Method

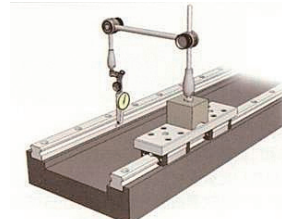

Table-1: Screw Tightening Torque (for SCM Material)

Type	Nominal of Thread	Recommended Torque (N · m)
Medium/Heavy Load Type	M3	2.0
	M5	8.8
	M6	12.7
	M8	29.4
Miniature Type	M2	0.4
	M2.5	0.6
	M3	1.0
	M4	2.5

Maintenance (Grease Application)

- Grease forms lubricating film between steel balls and rolling surface of linear guides. This reduces friction and prevents seizures. Grease loss and deterioration will cause shorter life of linear guides. Apply grease appropriately depending on your condition of use. Grease listed below is applied to MISUMI Linear Guides before shipping, and the products can be used out of box.
- Miniature Type: Filled with Lithium soap based grease (Multemp Grease PS2 by Kyodo Yushi Co., Ltd.).
- Medium/Heavy Load Type: Filled with Lithium soap based grease (Alvania Grease S2 by Showa Shell Sekiyu K.K.).
- Recommended Lubrication Intervals: Every 6 month
 - Every 3 month when travel distance is extensive, or every 1000km.
 - *Recommended above is the lubrication interval based on travel distance. If the grease degrades or gets contaminated faster depending on the operating environment, you will need to shorten the lubrication interval as needed.
- Lubrication Unit **MX** significantly extends lubrication intervals.

Lubrication Units Which Provide Long-term Maintenance-free Operation **MX**

Lubrication Unit **MX** Structure

Enlarged Photos of Special Polyurethane Pores

•Before grease is impregnated

•After grease is impregnated

Special polyurethane, which is formed by continuous pore evenly distributed, highly excels in water-holding capability. Thus, it is possible to impregnate a large amount of grease.

Features

- Long Term Maintenance-free Condition**
Lubrication Unit **MX** is a self-lubrication unit constructed of grease impregnated special polyurethane. Capillary action provides appropriate supply of grease to the track surface of the linear guide. Oil film is always formed between the steel ball and the rail and provides long term maintenance-free operation.
- Cost Advantages**
Since lubrication frequency can be significantly reduced, you can save maintenance cost.