

SLIDE TYPE AIR NIPPERS

-HORIZONTAL SLIDE TYPE-

Blade sold separately

shows in red

■ Horizontal Slide Type



⚠ The blade is sold separately. Note that there are a regular blade and a reverse blade.

MGT-NY□□ (Pull type)
MGT-NY□□R (Push type)

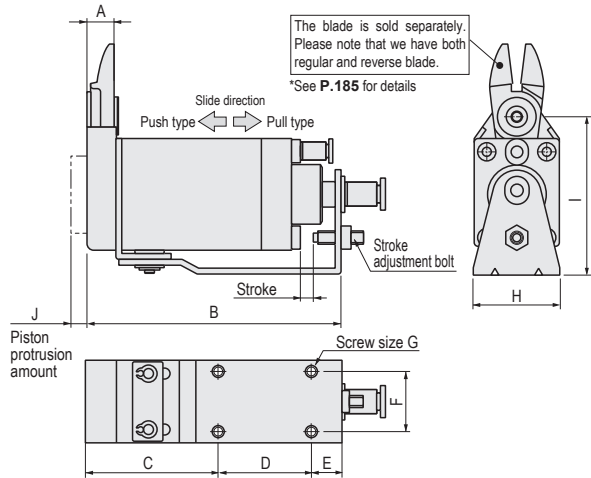

Cutting capacity φ (mm)		Air consumption (cm ³ /time)	Weight (g)	Slide type/stroke (mm)	Part dimensions (mm)										Tube Outer x Inner	Hose Port	Part Number	Unit Price 1-9 pcs
Soft resin	Hard resin				A	B	C	D	E	F	G	H	I	J				
3.0	2.0	48.0	155.0	Pull 0-3	8.6	75.9	40.9	25.0	10.0	15.0	M4	23.0	47.6	3.0	4 x 2.5	Hose nipple	MGT-NY05	Quotation
				Push 0-3												MGT-NY05R		
				Tube fitting												MGT-NY05-4		
3.5	2.3	68.0	210.0	Pull 0-3	8.8	82.1	42.1	30.0	10.0	20.0	M4	28.0	51.6	5.0	4 x 2.5	Hose nipple	MGT-NY10	
				Push 0-3												MGT-NY10R		
				Tube fitting												MGT-NY10-4		
4.0	2.6	136.0	319.0	Pull 0-3	10.2	93.0	48.0	35.0	10.0	25.0	M4	33.0	58.0	5.0	4 x 2.5	Hose nipple	MGT-NY15	
				Push 0-3												MGT-NY15R		
				Tube fitting												MGT-NY15-4		
5.0	3.4	184.0	580.0	Pull 0-5	12.5	108.5	54.5	40.0	14.0	30.0	M5	42.0	69.0	2.0	6 x 4	Hose nipple	MGT-NY25	
				Push 0-5												MGT-NY25R		
				Tube fitting												MGT-NY25-6		

• Operating air pressure: 0.4-0.5 MPa (only MGT-NY25 type: 0.5-0.6 MPa)

⚠ For quantities not displayed here, refer to our MISUMI website for more information.



Order

Part Number
MGT-NY05
MGT-NY05R-4



Days to Ship

Quotation



Price

Quotation