

PUSHERS

—REGULAR TYPE—

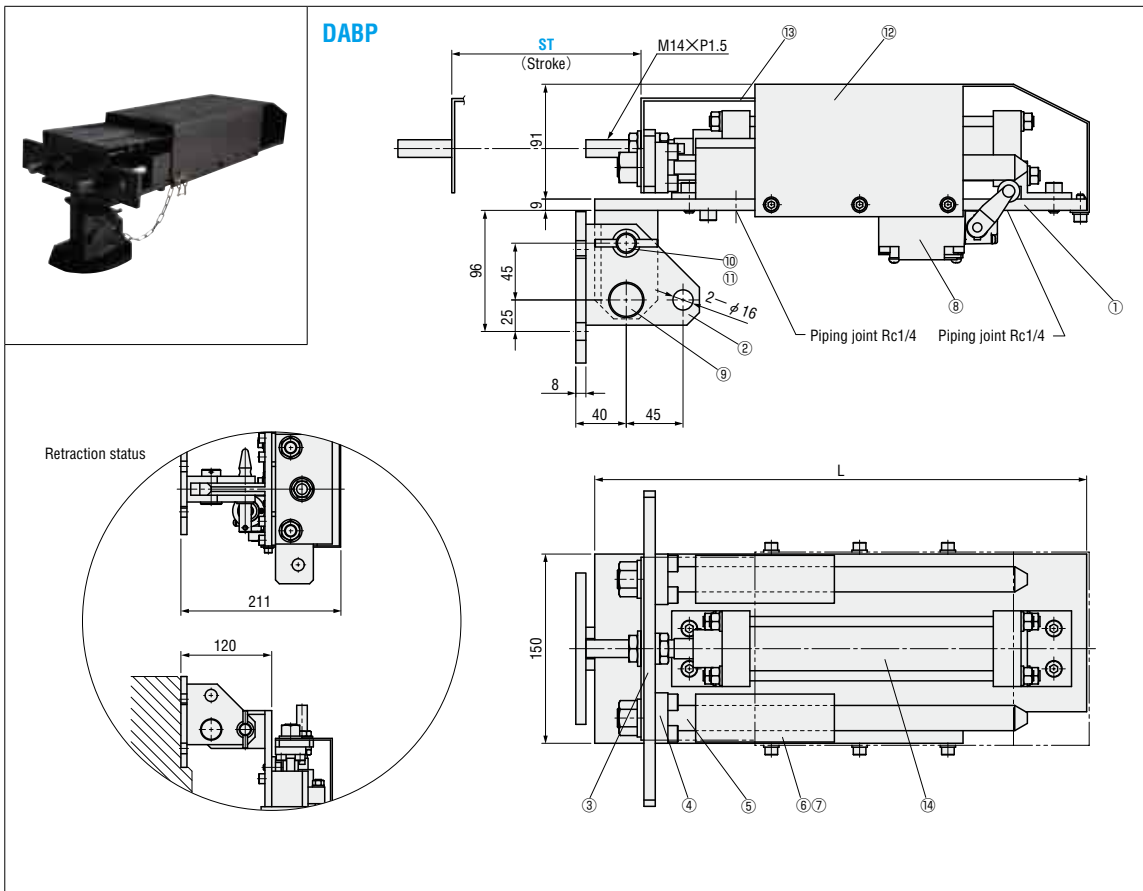



Components list

No.	Name	Qty.	Material & remarks
①	Baseplate	1	Equivalent to SS400
②	Bracket	1	Equivalent to SS400
③	Connector plate	1	Equivalent to SS400
④	Fixed plate	2	Equivalent to SS400
⑤	Guide pin	2	S45C
⑥	Guide bushing holder	2	S45C
⑦	Guide bushing	4	Oil-free
⑧	Limit switch	1	
⑨	Link pin	1	S45C
⑩	Stop pin	1	S45C
⑪	Chain	1	Length 200mm
⑫	Cover	1	SPC
⑬	Cover	1	SPC
⑭	Cylinder	1	Special product

L	Catalog No.	Stroke ST
390	DABP	150
490		250

- When using**
- Can be used for folding and storage of die.
 - For compressing small and medium parts.

Order  **Catalog No.** DABP **ST** 150

Days to Ship  **Quotation**

Price  **Quotation**

PUSHERS

—COMPACT TYPE—

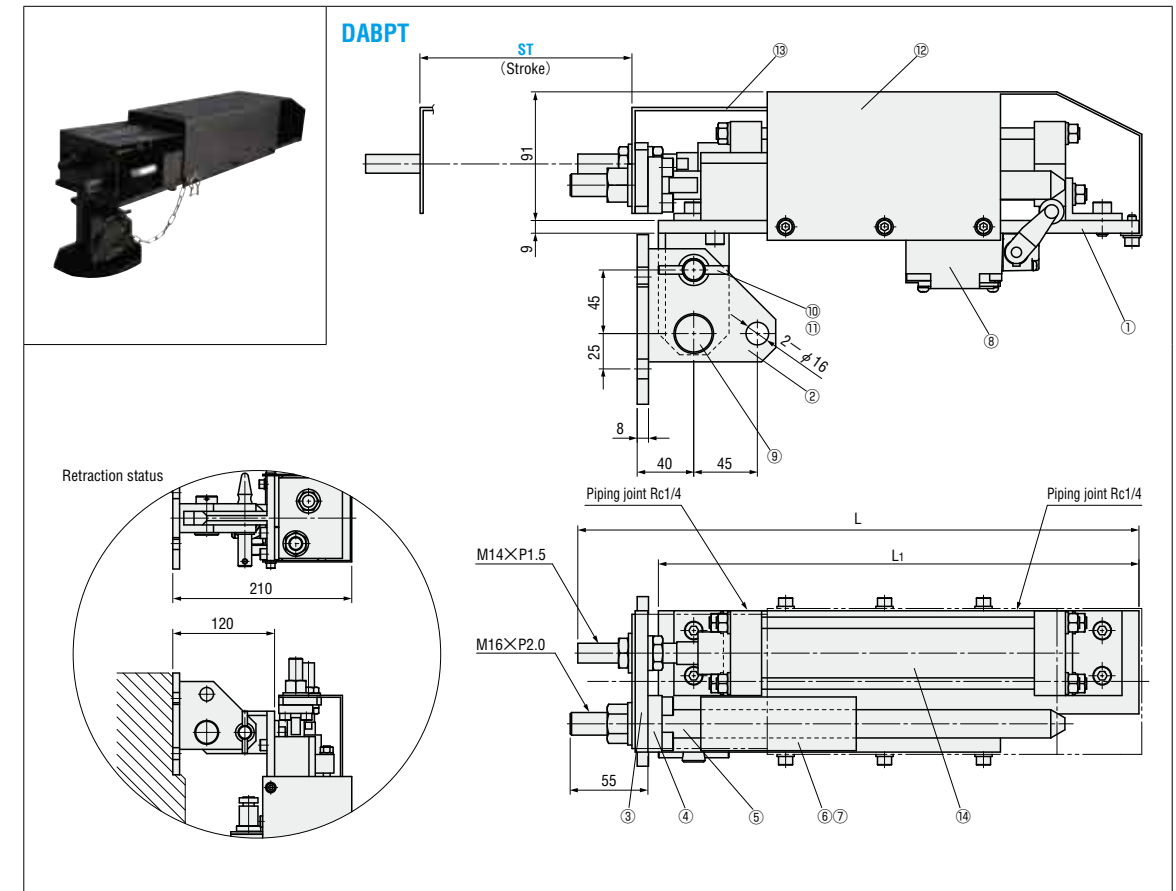



Components list

No.	Name	Qty.	Material & remarks
①	Baseplate	1	Equivalent to SS400
②	Bracket	1	Equivalent to SS400
③	Panel	1	Equivalent to SS400
④	Fixed plate	1	Equivalent to SS400
⑤	Guide bar	1	S45C
⑥	Guide bushing holder	1	Equivalent to SS400
⑦	Guide bushing	2	Oil-free
⑧	Limit switch	1	
⑨	Link pin	1	S45C
⑩	Stop pin	1	S45C
⑪	Chain	1	Length 200mm
⑫	Cover	1	SPC
⑬	Cover	1	SPC
⑭	Cylinder	1	Special product

L	L1	Catalog No.	Stroke ST
395	340	DABPT	150
495	440		250

- When using**
- Can be used for folding and storage of die.
 - For compressing small and medium parts.

Order  **Catalog No.** DABPT **ST** 150

Days to Ship  **Quotation**

Price  **Quotation**